

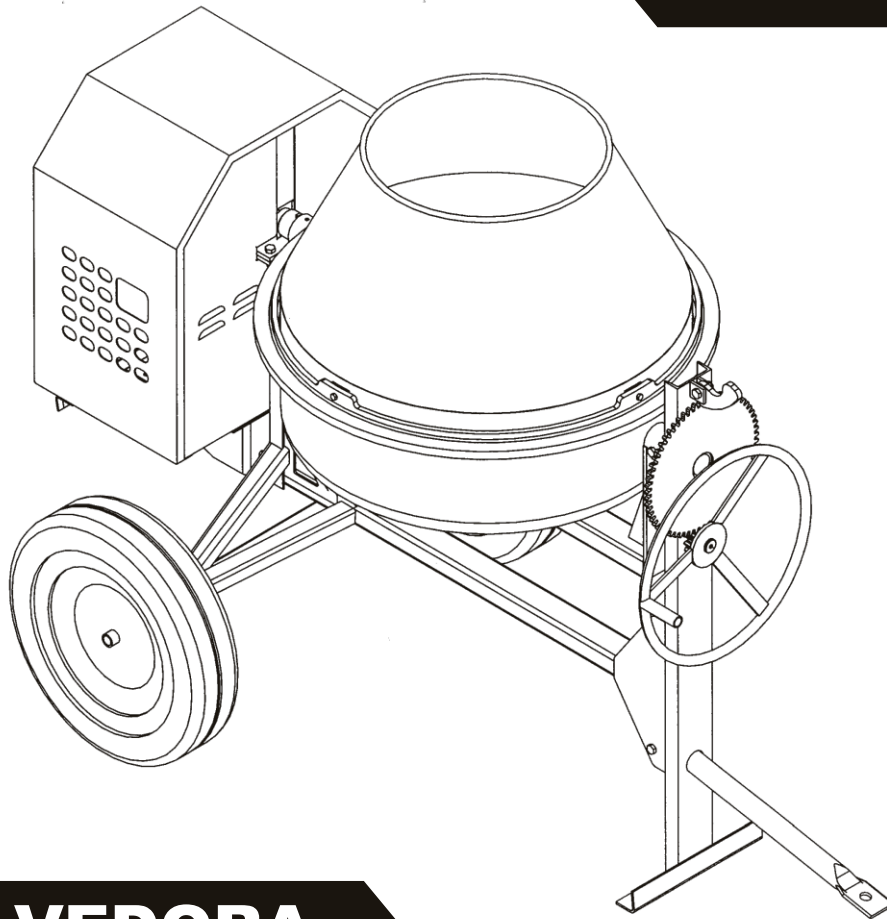

GRUPO CIPSA
CIMENTAMOS SU ÉXITO

www.CIPSA.com.mx



REVOLVEDORA PARA CONCRETO

Modelo MAXI-10ND

Lista de PARTES

Manual No. 516684
Revisión: 6
Enero 2016

www.CIPSA.com.mx

Índice

Ensamble Motor	3
Ensamble Chasis	5
Ensamble Olla Metal	7
Ensamble Caseta	9
Ensamble Olla Plástico	11
Kit Olla Plástico	13
Ensamble Mesa Motor y llantas	15

Estamos para servirle:

Carretera Federal México-Puebla, Km 126.5
Momoxpan, Cholula, Pue. MEXICO CP 72760
Tel [+52 222] 225 99 00 Ext 9121 y 9122

CI-Equip-Export@cipsa.com.mx
VENTAS EXPORTACIÓN Y ASESORÍA TÉCNICA

CI-Rep-Export@cipsa.com.mx
CI-Postvta-Export@cipsa.com.mx
SOPORTE POST-VENTA Y REPUESTOS ORIGINALES

www.CIPSA.COM.MX

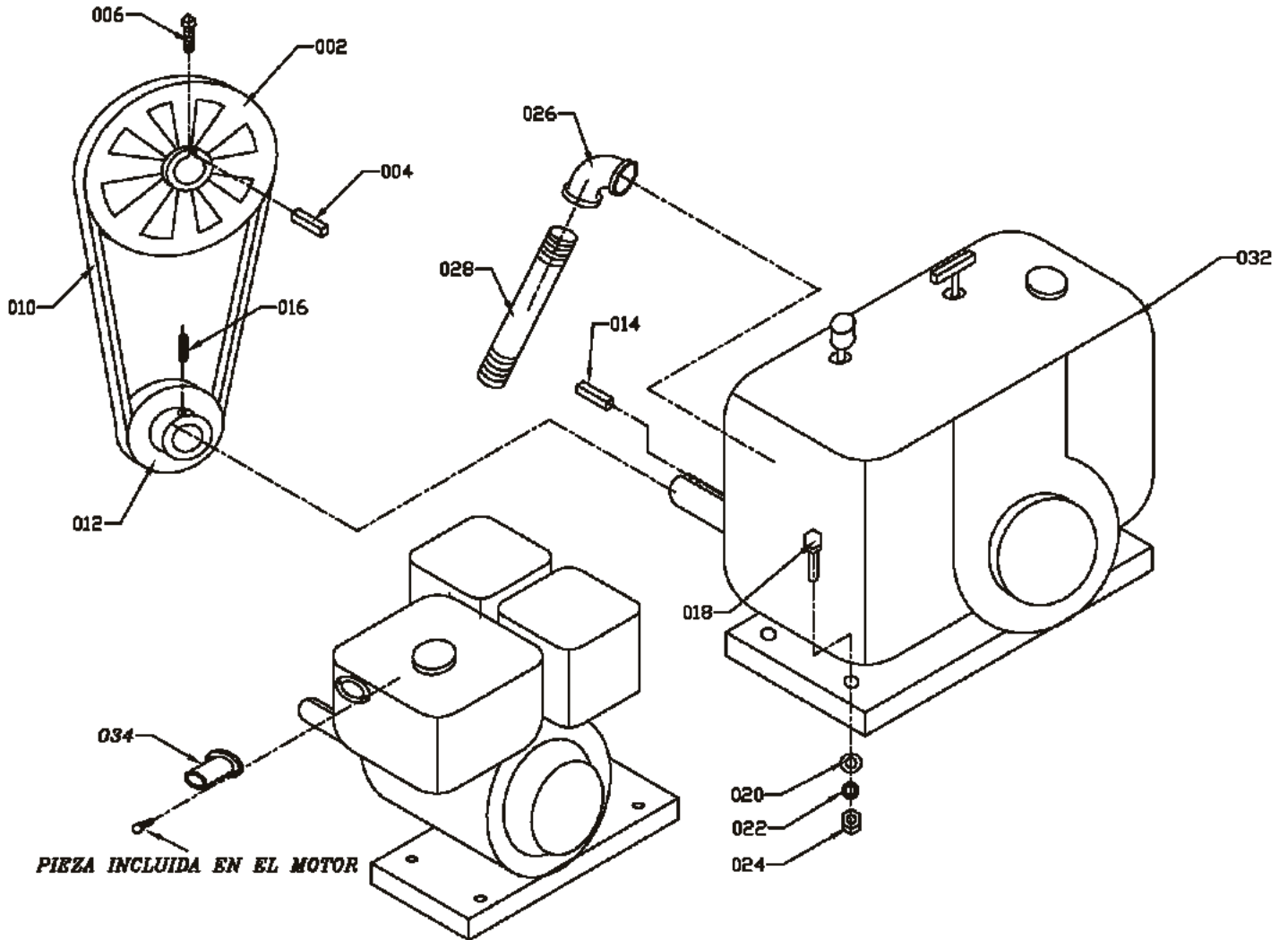
Ensamble Motor

Ensamble Motor

SECUENCIA	CODIGO	DESCRIPCION	CANTIDAD	
2	CIP514060	POLEA S-B 1R 406.4MM FLECHA 25MM (CAD)	1	
4	CIP500275	CUÑA 1/4" X 40 MM (CAD)	1	
6	CIP492476J	OPR.S. 5/16""NC X 3/4"" G. (CAD)	2	
10	CIP504107	BANDA V SECCION B-54	1	PARA KOHLER 12HP
	CIP493399	BANDA V SECCION B-55	1	PARA HONDA 8HP, 13HP,MPOWER 9HP, 13HP; KOHLER 9HP, 14HP; ROBIN 9HP
	CIP512265	BANDA V SECCION B-59	1	PARA ELECTRICO 2HP/3F; ELECTRICO 2HP/1F
	CIP504076	BANDA V SECCION B-57	1	PARA BRIGGS 8HP; ROBIN 7HP
	CIP504233	BANDA V SECCION B-56	1	PARA KOHLER 8HP
12	CIP504077	POLEA S-B 1R 63.5 MM FLECHA 28.6MM (CAD)	1	PARA KOHLER 12HP
	CIP504075	POLEA S-B 1R 63.5 MM FLECHA 25.4MM (CAD)	1	PARA HONDA 8HP, 13HP, BRIGGS 8HP; MPOWER 9HP, KOHLER 8HP, 9HP, 14HP; ROBIN 9HP
	CIP512261	POLEA S-B 1R 114 MM FLECHA 28.5MM (CAD)	1	PARA ELECTRICO 2HP/3F
	CIP514923	POLEA S-B 1R 78 MM FLECHA 22.4MM (CAD)	1	PARA ELECTRICO 2HP/1F
	CIP517701	POLEA S-B 1R 63.5 MM FLECHA 25 MM (CAD)	1	PARA MPOWER 13HP
	CIP508312	POLEA S-B 1R 63.5 MM FLECHA 19.1MM (CAD)	1	PARA ROBIN 7HP
14	CIP500275	CUÑA 1/4" X 40 MM (CAD)	1	
	CIP501019	CUÑA 3/16" X 45 MM (CAD)	1	PARA ROBIN 7HP
16	CIP492468J	OPR.A. 5/16""NC X 1/2"" MOL. G. (CAD)	1	
18	CIP492378J	TOR.C/H 3/8""NC X 1.3/4"" G5 G. (CAD)	4	
	CIP492313J	TOR.C/H 3/8""NC X 1.1/2"" G5 G. (CAD)	4	PARA KOHLER 8HP
	CIP492364J	TOR.C/H 5/16""NC X 1"" G5 G. (CAD)	4	PARA ELECTRICO 2HP/1F
	CIP492367J	TOR.C/H 5/16""NC X 1.3/4"" G5 G. (CAD)	4	PARA BRIGGS 8HP, ROBIN 7HP
20	CIP492598J	RONDANA 3/8"PLANA G. 25-10.4-2.2MM (CAD)	4	
	CIP492597J	RONDANA 3/8"PLANA G.22.3-9.6-1.9MM (CAD)	8	PARA ELECTRICO 2HP/1F; BRIGGS 8HP; ROBIN 7HP
22	CIP492624J	RONDANA 3/8""PRESION G. (CAD)	4	
	CIP492623J	RONDANA 5/16""PRESION G. (CAD)	4	PARA ELECTRICO 2HP/1F; BRIGGS 8HP; ROBIN 7HP
24	CIP492554J	TUERCA 3/8""NC HEX. G5 G. (CAD)	4	
	CIP492553J	TUERCA 5/16""NC HEX. G5 G. (CAD)	4	PARA ELECTRICO 2HP/1F; BRIGGS 8HP; ROBIN 7HP
26	CIP491160	CODO G. 90G 1"	1	PARA KOHLER 12HP
28	CIP504249	NIPLE 1"NPT X 3" GALV.	1	PARA KOHLER 12HP
30	CIP490482	ACEITE SAE-30		
32	CIP493162	MOTOR KOHLER M12HP BASICO	1	
	CIP514888	MOTOR HONDA 8HP GX240UT2-QA-2	1	
	CIP521387	MOTOR HONDA 9HP GX270H-QK	1	
	CIP3364	MOTOR HONDA 13HP BASICO 390UT2-QA2	1	
	CIP521388	MOTOR HONDA 13HP GX390H1-QK	1	
	CIP512268	MOTOR ELECTRICO 2HP 3F 1165RPM	1	
	CIP516160	MOTOR ELECTRICO WEG 2HP 110, 220V	1	
	CIP493178	MOTOR BRIGGS 8HP BASICO	1	
	CIP513969	MOTOR MPOWER 9HP BASICO	1	
	CIP514872	MOTOR MPOWER 13HP BASICO	1	
	CIP493157	MOTOR KOHLER 8HP BASICO	1	
	CIP521144	MOTOR KOHLER 9.5 HP	1	SUSTITUYE AL KOHLER 8HP
	CIP521143	MOTOR KOHLER 14HP	1	SUSTITUYE AL KOHLER 12 HP
	CIP515154	MOTOR ROBIN 7HP Ex210	1	
	CIP521113	MOTOR ROBIN 9HP FLECHA DE 1"	1	
34	CIP517697	TUBO DE ESCAPE MOTOR ROBIN 7HP	1	PARA ROBIN 7HP
	CIP520678	TUBO ESCAPE CONCRETERAS ROBIN 9HP	1	PARA ROBIN 9HP

Ensamble Chasis

NOTA: APLICAR SELLADOR DE TORNILLERIA ROJO REMOVIBLE N°118

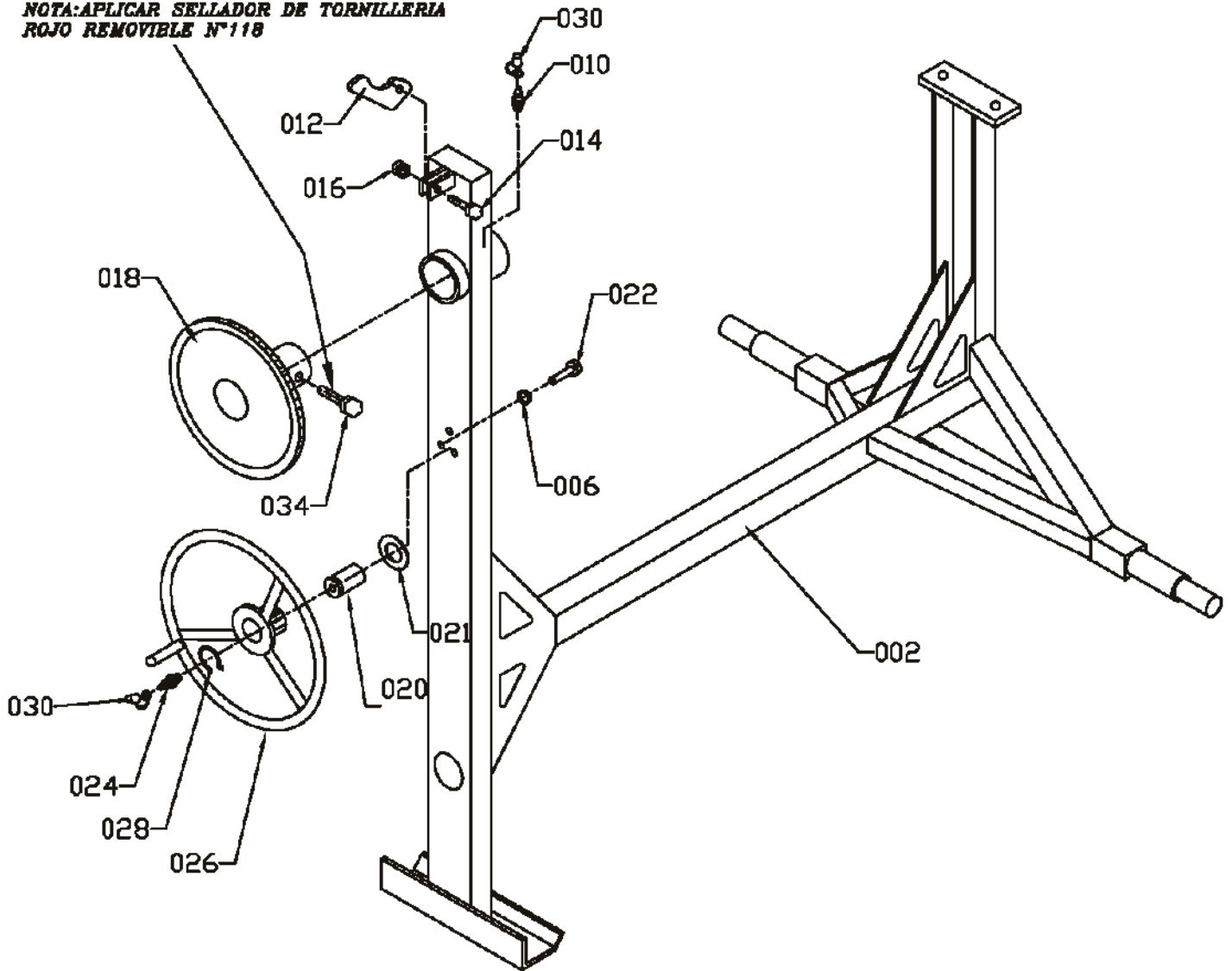

Ensamble Chasis

SECUENCIA	CODIGO	DESCRIPCION	CANTIDAD
2	CIP516560	CHASIS MAXI-10 2006	1
6	CIP492623J	RONDANA 5/16""PRESION G. (CAD)	3
10	CIP491698J	GRASERA 1/8""NPT RECTA (CAD)	1
12	EM490895	PALANCA DE BLOQUEO Espesor 1/2"	1
14	CIP492329J	TOR.C/H 1/2""NC X 1.3/4"" G2 G. (CAD)	1
16	CIP492584J	TUERCA 1/2""NC INS. NYLON G5 G. (CAD)	1
18	CIP516668	CATARINA MAXI 2006	1
20	CIP516534	EJE PIÑON VOLANTE MAXI-10	1
21	CIP504447J	RONDANA 1.1/4"PLANA G. 57-32-3.6MM (CAD)	1
22	CIP492259J	TOR.C/A 5/16""NC X 3/4"" G8.8 G. (CAD)	3
24	CIP491698J	GRASERA 1/8""NPT RECTA (CAD)	1
26	CIP514002	VOLANTE MAXI-10 REM.*	1
28	CIP513642J	ANILLO RETENCION 5133-118 (CAD)	1
30	CIP491008	CUBRE GRASERA A. D 1/8"	2
34	CIP492393J	TOR.C/H 1/2""NC X 1.1/4"" G5 G. (CAD)	2
36	CIP492584J	TUERCA 1/2""NC INS. NYLON G5 G. (CAD)	2

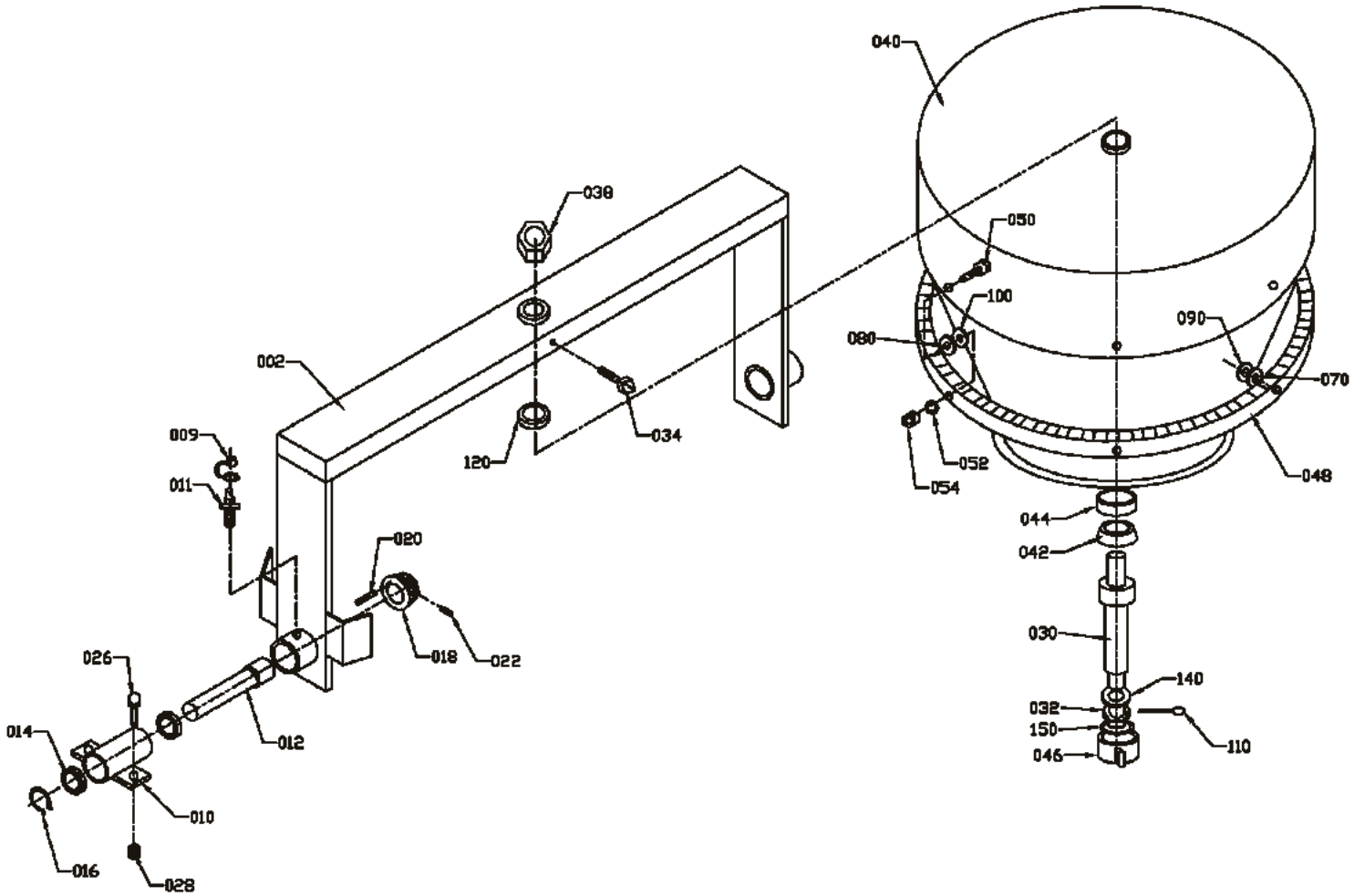
Ensamble Olla Metal

Ensamble Olla Metal

SECUENCIA	CODIGO	DESCRIPCION	CANTIDAD	
2	CIP516654	HORQUILLA MAXI-10ND	1	
9	CIP491008	CUBRE GRASERA A. D 1/8"	1	
10	CIP514036	CHUMACERA MAXI-10	1	
11	CIP491698J	GRASERA 1/8"NPT RECTA (CAD)	1	
12	CIP513991	EJE MOTRIZ MAXI-10 REM.	1	
14	CIP492178	RODAMIENTO 6005-2RS BOLAS 1H (CAD)	2	
16	CIP490970J	ANILLO RETENCION 5100-98 (CAD)	1	
18	CIP804293	PIÑON CONICO*	1	
20	CIP500275	CUÑA 1/4" X 40 MM (CAD)	1	
22	CIP492468J	OPR.A. 5/16"NC X 1/2" MOL. G. (CAD)	2	
26	CIP492394J	TOR.C/H 1/2"NC X 1.1/2" G5 G. (CAD)	2	
28	CIP492584J	TUERCA 1/2"NC INS. NYLON G5 G. (CAD)	2	
30	CIP516495	EJE MAQUINADO OLLA METAL MAXI-10ND	1	
32	CIP516678CJ	TUERCA 1.1/4"NF CASTILLO MAQ. G. (CAD)	1	
34	CIP492491J	OPR.S. 1/2"NC X 1.1/2" G. (CAD)	1	
38	CIP516614J	TUERCA 1.1/2"NF HEX. FORJADA G. (CAD)	1	
40	CIP516575	OLLA 9 CU FT MAXI-10ND REFACCION	1	
	CIP801233	OLLA 9 CU FT BOCA CHICA (367lt)REFACCION	1	A PARTIR No. SERIE MM1107001
	CIP521254	OLLA 9 CU FT BOCA CHICA (380 LITROS)	1	A PARTIR No. SERIE MM1210077
42	CIP510955	RODAMIENTO 2788 CONICO 1H	2	
44	CIP510956	TAZA 2720 KOYO PARA RODAMIENTO	2	
46	CIP516511	TAPON TUBO OLLA MAQUINADO	1	
48	CIP516658	CORONA 4BAR 163 DIENTES LIGERA	1	
50	CIP492313J	TOR.C/H 3/8"NC X 1.1/2" G5 G. (CAD)	6	
52	CIP492624J	RONDANA 3/8"PRESION G. (CAD)	6	
54	CIP492542J	TUERCA 3/8"NC HEX. G2 G. (CAD)	6	
70	CIP511729C	CALZA CORONA OLLA CAL.10	3	
90	CIP511730C	CALZA CORONA OLLA CAL.14	1	
100	CIP511731C	CALZA CORONA OLLA 3/16"	1	
110	CIP491690J	CHAVETA 5/32" X 2" G. (CAD)	1	
120	CIP516592	RETEN C/R 22327	1	
140	CIP504447J	RONDANA 1.1/4"PLANA G. 57-32-3.6MM (CAD)	1	
150	CIP516618	O-RING 2-234 PARKER DI=75.8 W=3.53 (CAD)	1	

Ensamble Caseta

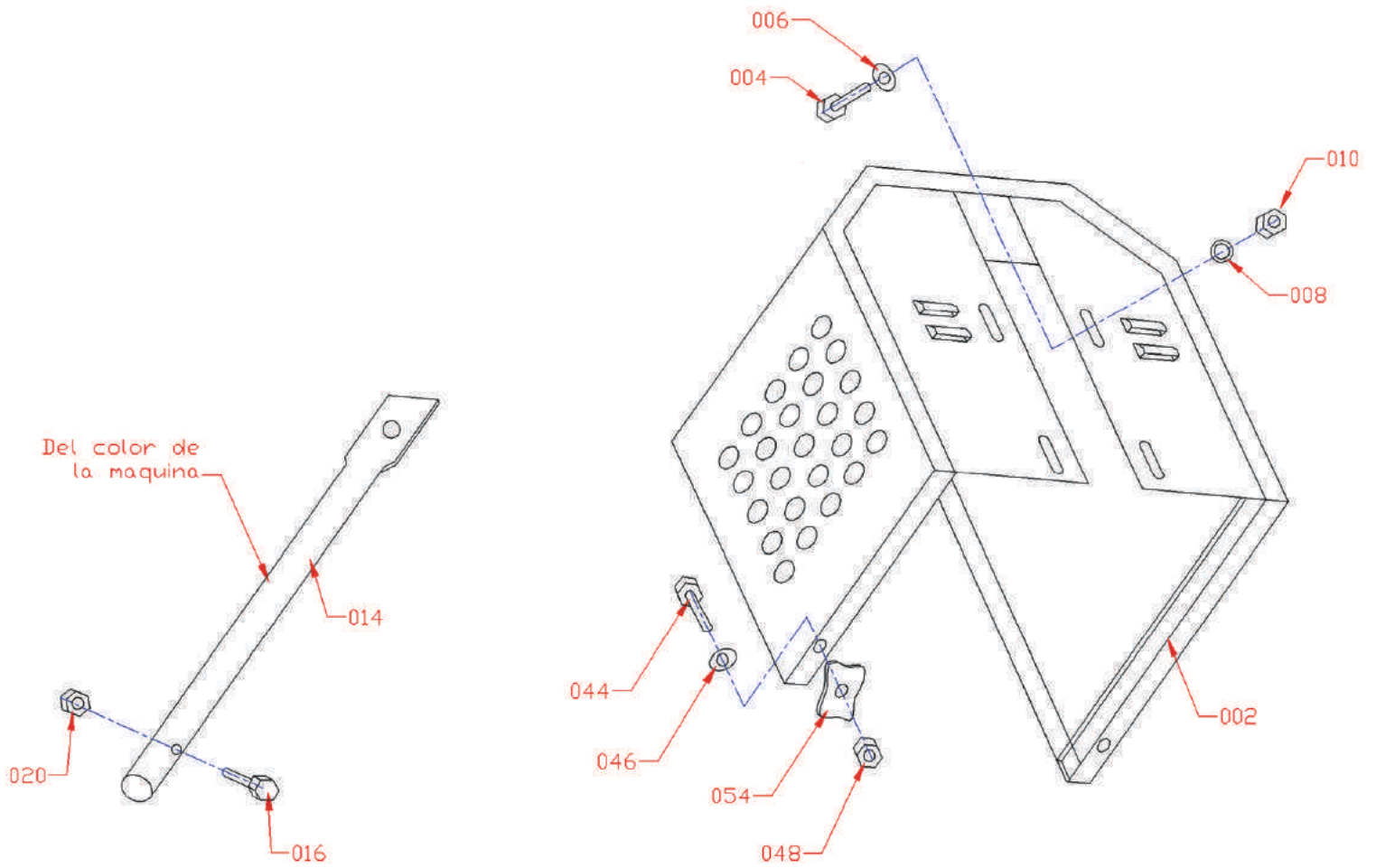

Ensamble Caseta

SECUENCIA	CODIGO	DESCRIPCION	CANTIDAD
2	CIP514052	CASETA MAXI-10	1
4	CIP492357J	TOR.C/H 1/4"NC X 1" G5 G. (CAD)	4
6	CIP492596J	RONDANA 5/16"PLANA G. 18.6-8-1.6MM (CAD)	4
8	CIP492622J	RONDANA 1/4"PRESION G. (CAD)	4
10	CIP492561J	TUERCA 1/4"NC HEX. G5 G. (CAD)	4
14	CIP514158	BARRA REMOLQUE MAXI-10	1
16	CIP503111J	TOR.C/H 1/2"NC X 4.1/2" G5 G. (CAD)	1
20	CIP492584J	TUERCA 1/2"NC INS. NYLON G5 G. (CAD)	1
30	CIP512915J	CALC. PINTURA EN POLVO	1
34	CIP516684	MANUAL MAXI-10ND	1
40	CIP520285J	CALC. CIPSA S/LOGOTIPO (275mm)	2
44	CIP492312J	TOR.C/H 3/8"NC X 1.1/4" G2 G. (CAD)	2
46	CIP492598J	RONDANA 3/8"PLANA G. 25-10.4-2.2MM (CAD)	2
48	CIP492583J	TUERCA 3/8"NC INS. NYLON G8 G. (CAD)	2
54	CIP501028	AMORTIGUADOR CASETA	2
60	CIP516177J	CALC. PLASTIFICADA 01 800	1
70	CIP517691J	CALC. ARRANQUE MAXI-10ND	1
80	CIP517610J	CALC. MANTTO/TRANSPORTE CO10	1
90	CIP518523J	CALC. ISO 9001:2000 NACIONAL	1
100	CIP521214J	CALC. MAXI-10 (155X20MM)	2

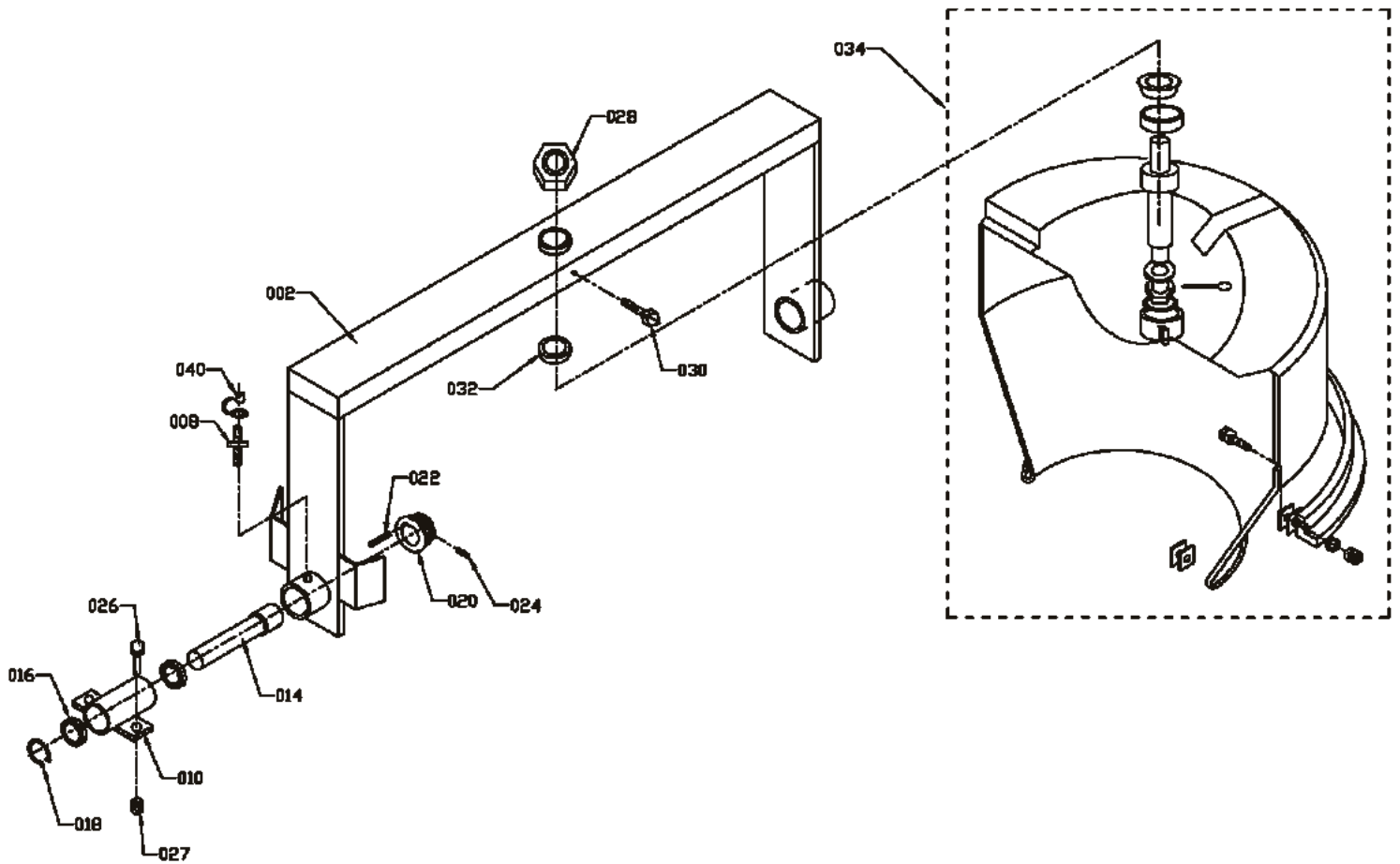
Ensamble Olla Plástico

Ensamble Olla Plástico

SECUENCIA	CODIGO	DESCRIPCION	CANTIDAD
2	CIP516654	HORQUILLA MAXI-10ND	1
8	CIP491698J	GRASERA 1/8" NPT RECTA (CAD)	1
10	CIP514036	CHUMACERA MAXI-10	1
14	CIP513991	EJE MOTRIZ MAXI-10 REM.	1
16	CIP492178	RODAMIENTO 6005-2RS BOLAS 1H (CAD)	2
18	CIP490970J	ANILLO RETENCION 5100-98 (CAD)	1
20	CIP804293	PIÑON CONICO*	1
22	CIP500275	CUÑA 1/4" X 40 MM (CAD)	1
24	CIP492468J	OPR.A. 5/16" NC X 1/2" MOL. G. (CAD)	2
26	CIP492394J	TOR.C/H 1/2" NC X 1.1/2" G5 G. (CAD)	2
27	CIP492584J	TUERCA 1/2" NC INS. NYLON G5 G. (CAD)	2
28	CIP516614J	TUERCA 1.1/2" NF HEX. FORJADA G. (CAD)	1
30	CIP492491J	OPR.S. 1/2" NC X 1.1/2" G. (CAD)	1
32	CIP516592	RETEN C/R 22327	1
34	CIP516705	KIT OLLA MAXI-10ND PLASTICO	1
40	CIP491008	CUBRE GRASERA A. D 1/8"	1

Kit Olla Plástico

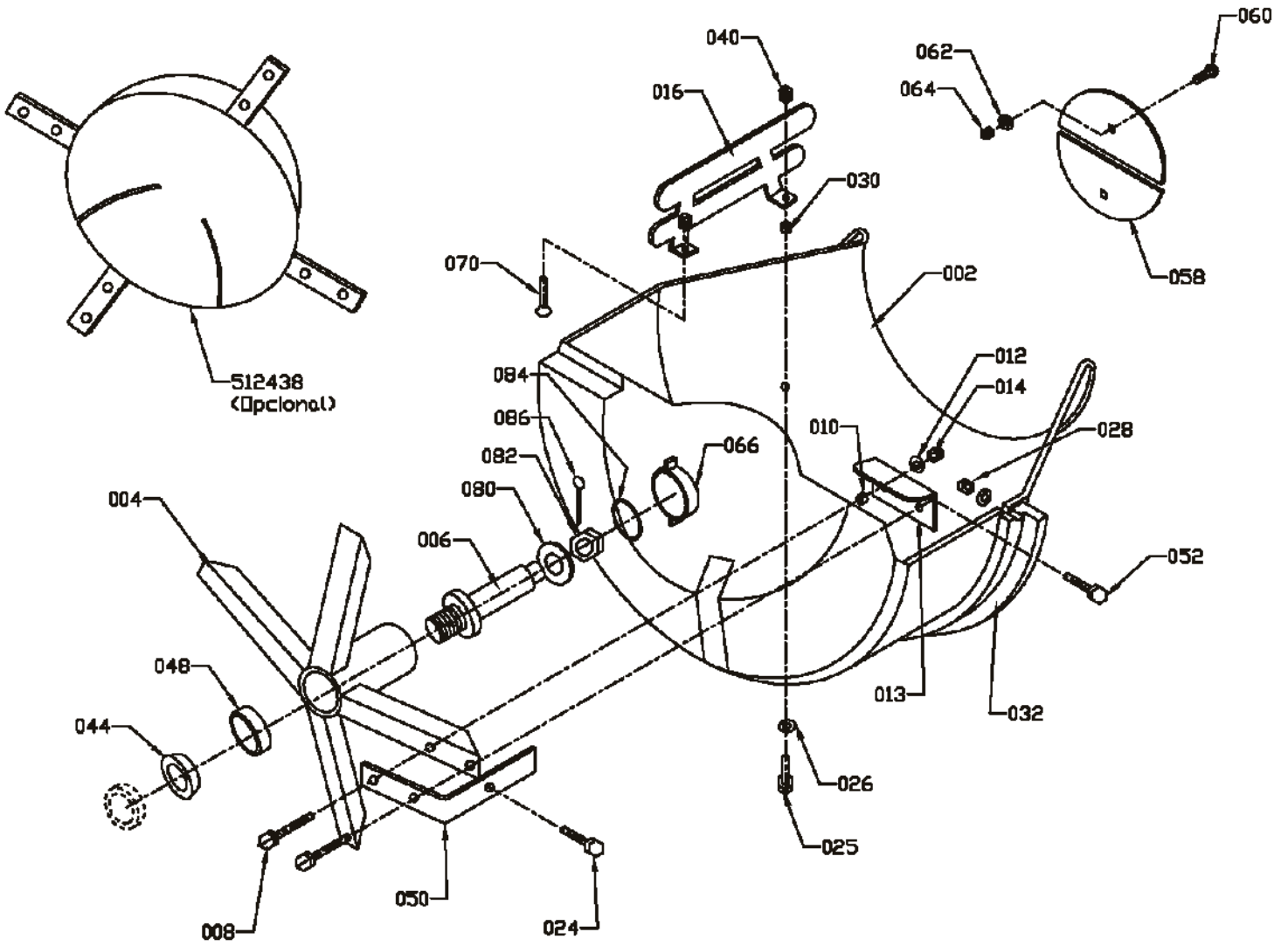

Kit Olla Plástico

SECUENCIA	CODIGO	DESCRIPCION	CANTIDAD
2	CIP510916	OLLA PLASTICO MAXI-10	1
4	CIP516706	SOPORTE DE OLLA MAXI-10NDP	1
6	CIP516504	EJE MAQUINADO OLLA POLY MAXI-10NDP	1
8	CIP503116J	TOR.C/H 3/8""NC X 3.3/4"" G5 G. (CAD)	8
10	CIP507538C	BUJE SEPARADOR OLLA PLAS.	8
12	CIP510909J	RONDANA 3/8"PLANA G.28.5-10.3-3.4MM(CAD)	8
13	CIP515305	FUNDA ANTIDESGASTE	4
14	CIP492583J	TUERCA 3/8""NC INS. NYLON G8 G. (CAD)	8
16	CIP510884	PALA MAXI-10P ACERO	3
24	CIP492313J	TOR.C/H 3/8""NC X 1.1/2"" G5 G. (CAD)	4
25	CIP492313J	TOR.C/H 3/8""NC X 1.1/2"" G5 G. (CAD)	3
26	CIP510909J	RONDANA 3/8"PLANA G.28.5-10.3-3.4MM(CAD)	3
28	CIP492583J	TUERCA 3/8""NC INS. NYLON G8 G. (CAD)	6
30	CIP507538C	BUJE SEPARADOR OLLA PLAS.	3
32	CIP516658	CORONA 4BAR 163 DIENTES LIGERA	1
40	CIP492583J	TUERCA 3/8""NC INS. NYLON G8 G. (CAD)	8
44	CIP510955	RODAMIENTO 2788 CONICO 1H	2
48	CIP510956	TAZA 2720 KOYO PARA RODAMIENTO	2
50	CIP520486	REFUERZO OLLA PLÁSTICO ULTRA	4
52	CIP492379J	TOR.C/H 3/8""NC X 2"" G5 G. (CAD)	4
58	CIP515304	PLATO ANTIDESGASTE	2
60	CIP505196J	TOR.C/CO 3/8""NC X 1.1/2"" G5 G. (CAD)	2
62	CIP492598J	RONDANA 3/8"PLANA G. 25-10.4-2.2MM (CAD)	2
64	CIP492583J	TUERCA 3/8""NC INS. NYLON G8 G. (CAD)	2
66	CIP516424	TAPON TUBO OLLA POLY MAQUINADO	1
70	CIP515453J	TOR.C/PR 3/8""NC X 1.1/2"" G5 G. (CAD)	3
80	CIP517134	R. PLANA 1 1/4" 1.9 MM ESPESOR	1
82	CIP516678CJ	TUERCA 1.1/4"NF CASTILLO MAQ. G. (CAD)	1
84	CIP516618	O-RING 2-234 PARKER DI=75.8 W=3.53 (CAD)	1
86	CIP491690J	CHAVETA 5/32"" X 2"" G. (CAD)	1

Ensamble Mesa Motor y Llantas

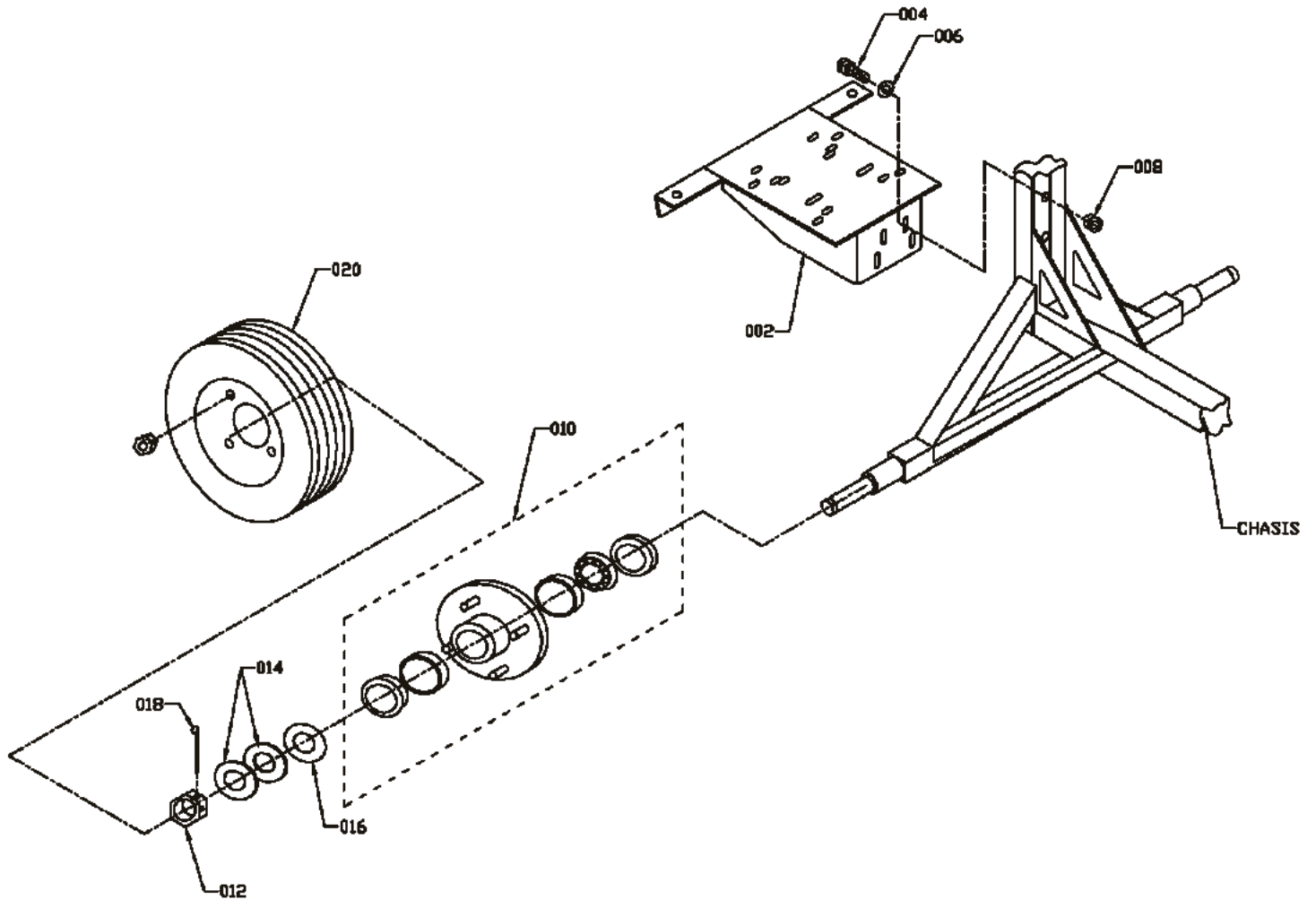

Ensamble Mesa Motor y Llantas

SECUENCIA	CODIGO	DESCRIPCION	CANTIDAD
2	CIP516648	MESA MOTOR MAXI 2006	1
4	CIP492394J	TOR.C/H 1/2"NC X 1.1/2" G5 G. (CAD)	4
6	CIP621J	RONDANA 1/2"PLANA G.28.4-13.4-4.8MM(CAD)	4
8	CIP492584J	TUERCA 1/2"NC INS. NYLON G5 G. (CAD)	4
10	EM941306A	MAZA C/ACCESORIOS (4 BIRLOS)	2
12	CIP502246J	TUERCA 1"-20UNEF CASTILLO G. (CAD)	2
14	CIP501299J	RONDANA 1"PLANA G. 45-26-3.4MM (CAD)	4
16	CIP511159J	RONDANA 1"PLANA G. 45-26-1.9MM (CAD)	2
18	CIP491688J	CHAVETA 1/8" X 1.1/2" G. (CAD)	2
20	CIP516476	LLANTA CON RIN 13	2

IMPORTANTE:

- Lea por completo el contenido de este manual.
- Es necesario que lo tenga a la mano en el momento de solicitar refacciones ya que deberá especificar:
 - Modelo de la máquina
 - Número de serie de la misma
 - Código de la pieza que necesita

 **GRUPOCIPSA**
CIMENTAMOS SU ÉXITO

www.CIPSA.com.mx

Estamos para servirle:



Carretera Federal México-Puebla, Km 126.5
Momoxpan, Cholula, Pue. MEXICO CP 72760
Tel [+52 222] 225 99 43 Ext 9121 y 9122

CI-Equip-Export@cipsa.com.mx
VENTAS EXPORTACIÓN Y ASESORÍA TÉCNICA

CI-Rep-Export@cipsa.com.mx
CI-Postvta-Export@cipsa.com.mx
SOPORTE POST-VENTA Y REPUESTOS ORIGINALES

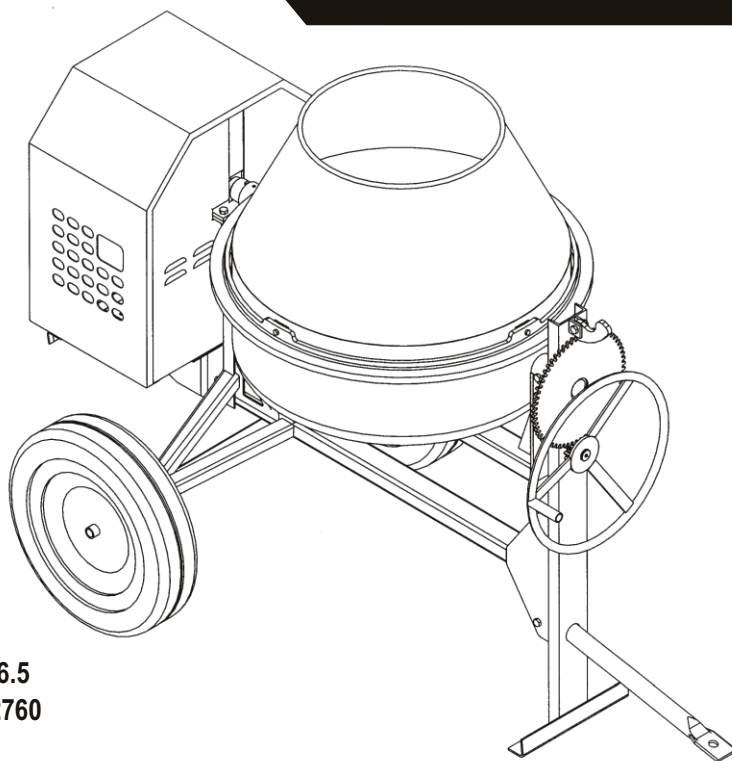

**REVOLVEDORA
PARA
CONCRETO**
Modelo MAXI-10ND

www.CIPSA.com.mx